



roon
tested
*pending

DSD
Direct Stream Digital

Hi-Res
AUDIO

MQA

M8x DAC

High-End DAC with Upsampling, Balanced Discrete Output Stage
& Headphone Amplifier

M8x DAC In Brief

DAC

- DAC Circuit: 32 bit Hyperstream II
- DAC Chip: 2x ES9038Q2M (dual differential)
- **NEW** Discrete balanced output stage
- **NEW** High-power balanced & discrete headphone amp
- **NEW** Balanced XLR headphone output
- **NEW** Drives power hungry and low impedance headphones down to 8 ohms with ease
- 16-core XMO5 and CPLD MAX II Altera processors
- Switchable Advanced Reclocking
- Switchable Upsampling
- Selectable Digital Filters
- Oversampling Bypass
- Full Hardware MQA Decoding for USB and SPDIF inputs
- Roon Tested
- Super Silent Power Transformer
- Discrete input power filtering and DC blocking circuitry

In & Output

- 1x Asynchronous USB: up to 768kHz
- USB: DSD 256 (stereo DoP), DSD512 (stereo native)
- 1x coaxial, 3x optical SPDIF; 1x AES/EBU: up to 24bit/192kHz
- 1x I2S for new Musical Fidelity CD Players
- 1x RCA, 1x balanced XLR outputs: variable/fixed switchable
- Trigger In/Out

Features

- Uncompromisingly rigid mechanical construction
- Front/side/top panels from extruded aluminium profile
- No display enables excellent shielding against outer electromagnetic fields and timeless looks
- Full aluminium buttons and control wheels

General Information

The M8x DAC proudly continues Musical Fidelity's legacy of pioneering world-class DAC technology.

Back in the early 90s, Musical Fidelity revolutionized audio performance by being one of the first to develop separate DACs to enhance CD player sound quality.

Today, in a world dominated by digital sources like PC audio and streamers - often built by software companies lacking hardware expertise - Musical Fidelity leads the way with its superior ability to transform digital signals into breathtaking analogue sound.

Built on the same core design principles as our acclaimed amplifiers, the M8x DAC delivers exceptional audio quality:

- **Class A** discrete analogue amplification for pure, detailed sound
- **No displays** to avoid unwanted electromagnetic interference
- **No WiFi or Bluetooth** for zero RF radiation and jitter-free performance
- **Toroidal transformers** for robust, clean power delivery
- **Solid mechanical construction** ensuring durability and premium build quality

Superlative Headphone Amplifier

The M8x DAC doesn't stop at DAC performance, it also boasts a high-end, ultra-powerful headphone amplifier capable of driving even the most demanding headphones with ease. Whether you're listening through speakers or headphones, experience the signature Musical Fidelity sound: soft yet powerful, clear, and effortlessly musical.



Technical Talk

Building on our knowledge and experience with Sabre ESS chips, the M8x DAC uses 2x ES-9038Q2M chips in dual differential mode for a pristine dual mono design. Thanks to these converters, the it supports up to 768 kHz files in PCM and DSD256 via DoP and native DSD512

via USB, covering any digital file you can buy or stream. The SPDIF inputs are greatly improved as well, now supporting MQA (up to 384kHz) and DSD (DoP 64) as well!

WM 8805 S/PDIF digital input chip

Fully balanced & discrete analogue output stage

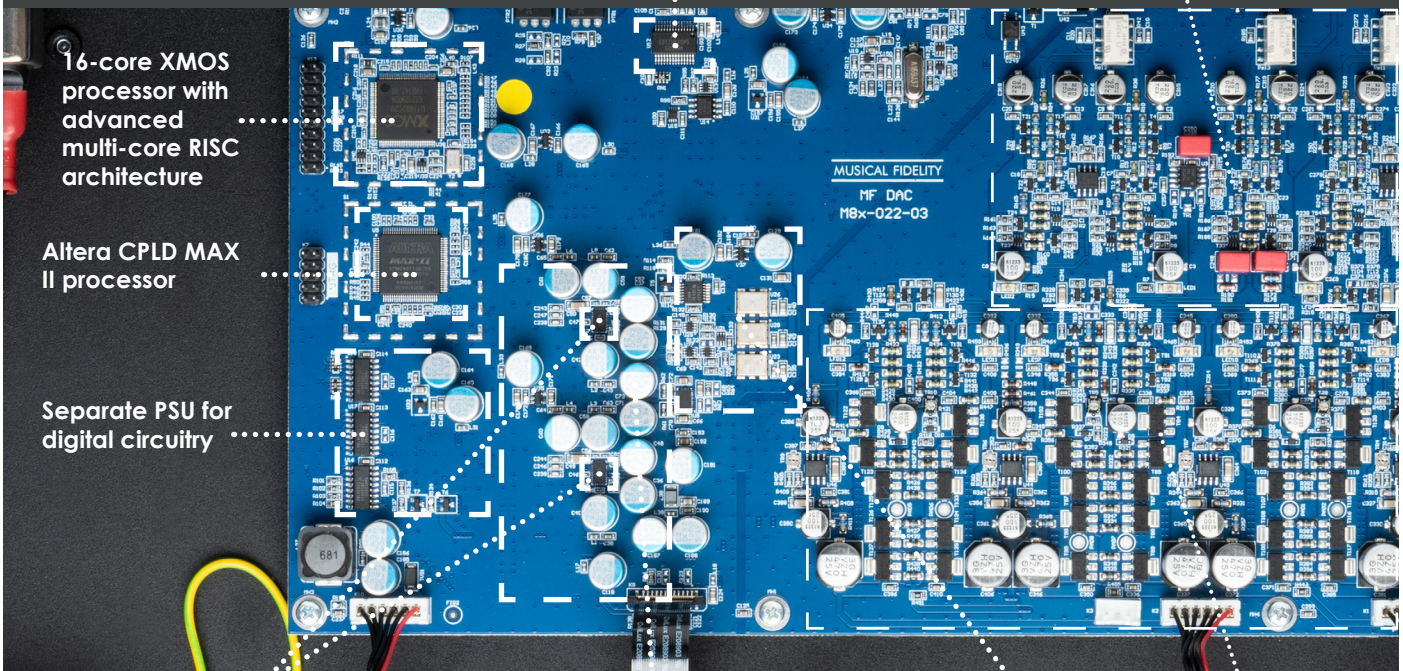

16-core XMOS processor with advanced multi-core RISC architecture

Altera CPLD MAX II processor

Separate PSU for digital circuitry

Dual ESS Sabre 9038 DACs

Separate PSU for analogue circuitry

Audio master clock and clock circuitry power supply

High-power fully balanced & discrete head-phone amp

Digital Architecture

We utilize an extremely low-noise, low-dropout regulator designed specifically for high-performance audio systems and optimized for high-resolution audio thanks to its revolutionary dual-regulator architecture. The inclusion of a Time Domain Jitter Eliminator results in superb SNR and THD+N performance with unbelievably detailed transient response.

Digital audio is the art of time, with our proprietary clock design we have managed jitter rates of unrivalled and below 100 femtoseconds. This outperforms many renowned and respected audiophile clock generators!

Other advances in the DAC section include optional upsampling and reclocking and an oversampling bypass mode. The 16-core XMOS and CPLD MAX II Altera processors ensure there is always enough headroom for these operations, the digital filters and the MQA processing.

Compared to the M6x DAC, MQA processing is now possible on the USB and SPDIF inputs!



Upsampling, Reclocking and Digital Filters

The CPLD MAX II (Complex Programmable Logic Device) Altera is used for re-clocking, which together with the XMOS microcontroller brings high-quality processing of both PCM, DSD and MQA technology. Upsampling and reclocking

can be individually turned on and off for PCM signals. DSD and MQA use their own format specific settings and filters. For PCM signals, the M8x DAC has eight selectable digital filters.

Oversampling Bypass

For ultra-high-res audio we have gone the extra step and created our oversampling bypass mode. This mode can be accessed by selecting filter 8 and is by default selected when the M8x DAC is first turned on after unpacking.

In this mode the DAC's oversampling FIR filters are disabled and source data is upsampled to 352,8kHz or 384kHz respectively.

Going even one step further, ultra-high sample rates of 705,6k and 768kHz enter the DAC

block directly. Effectively, this turns off all remaining filtering, improving audio parameters and the frequency spectrum by yet another step.

The oversampling filter is the largest single digital section "block" on the ESS DAC chip by silicon area. By powering this filter block down, we reduce the on-chip PSU / ground noise and consequently lower signal correlated clock modulation on the ESS DAC's silicon die.

Discrete and Fully Balanced Output

The M8x DAC bolsters a massively improved discrete output stage. Immediately noticeable by the enormous space requirements on the PCB – owing not only to the fact that it is fully discrete but also fully balanced - it is a major evolution compared to the M6x DAC's counterpart that was built using integrated circuits (=chips). This design also makes the M8x DAC truly fully balanced from beginning to end.

Not only is this benefitting sound characteristics, but also longevity and sustainability. The M8x DAC remains easy to maintain and repair as chips go eventually out of production and might not be replaceable many years later. But discrete components will always be built and can always be serviced.

Dual differential DAC section

Fully balanced & discrete analogue output stage

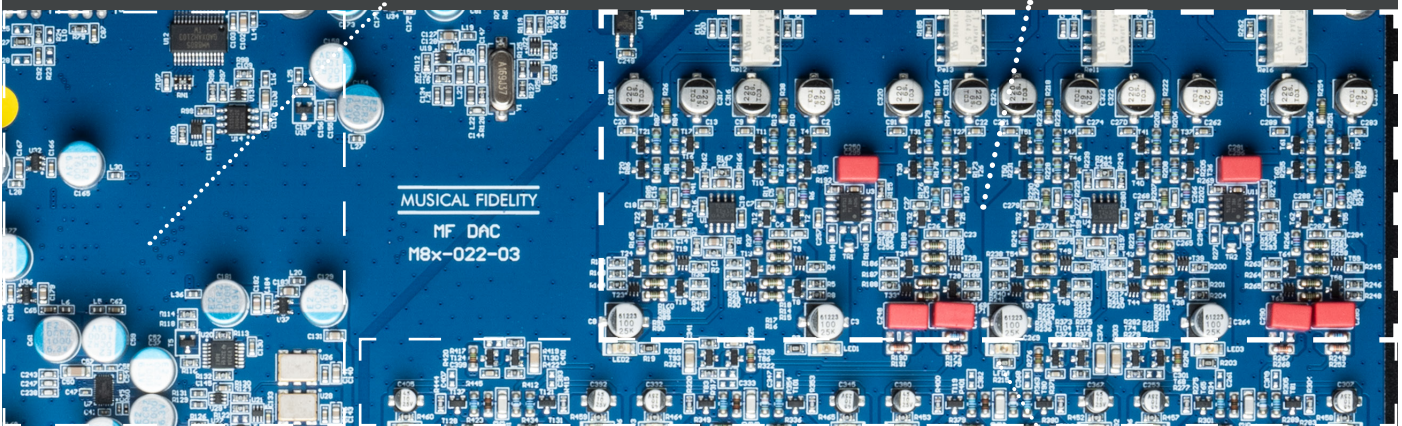

The Advantage of Discrete Circuits

A discrete circuit is composed of electronic components which are disparate, individual devices, also called discrete components. These can be “passive” components, like resistors, capacitors and inductors, as well as “active” components like transistors. The opposite to this would be an integrated circuit (IC = chip), which can, for example, be used as an operational amplifier (Op-Amp) in the signal chain.

In our industry we employ specialised IC Op-Amps built for audio applications, which allow us to produce very small and efficient electronics, as well as saving the time of design engineers. However, countless hours of listening tests and years of experience have shown

us that even the very best ICs do not tend to be so neutral, natural, dynamic or vivid – all of which are characteristics of the Musical Fidelity “sound”. They are also difficult - if not impossible - to repair. For that reason, we’re re-discovering our passion for traditional, discrete designs.

Where standard headphone amplifiers or output stages with integrated circuits have a few tens or hundreds of components, discrete designs will employ hundreds or thousands of components by comparison. That makes for an extended design process, but in our opinion results in the best sound for your money.

High-power fully balanced & discrete headphone amp

**High-power balanced & discrete:
The new M8x DAC headphone amp**

The M8x DAC features a headphone amplifier that outclasses many other stand-alone designs with ease.

Unlike almost all modern solutions that use chip-based designs, the M8x DAC incorporates a fully discrete design with DC coupled power operational amplifiers using transistors. Equipped with a 6.3mm jack output for unbalanced headphones, the M8x DAC also features a 4-pin XLR output for use with balanced headphones.

Balanced headphones get the full luxurious treatment. We are not just using a single ended amplifier with a fancy balanced XLR connector on the front. By using a fully differential balanced amplifier design, performance metrics are raised, achieving a mighty 3900 mW of power into 8 ohms, compared to 2000 mW with unbalanced headphones. Short time peaks way in excess of 10 Watts (for one cycle) are handled with ease.

And it gets even better. The amp has been carefully tuned to work completely in Class A up to full power for 30 ohms headphones or more. The terminal transistors used also allow the use of low load headphones down to 8 ohms, ensuring their high-current demand is comfortably met at all times.

Whether you're driving demanding low-impedance headphones or high-impedance studio-grade monitor headphones, the M8x DAC ensures a powerful, distortion-free experience. Its ability to handle load impedances as low as 8 ohms, while maintaining incredible clarity makes it a versatile choice for any audiophile. Balanced or unbalanced, the M8x DAC offers a jaw-dropping, awe-inspiring listening experience. The M8x DAC does not have "just a headphone amplifier" built in – truly, it's your gateway to Musical Fidelity.

Fully balanced & discrete analogue output stage

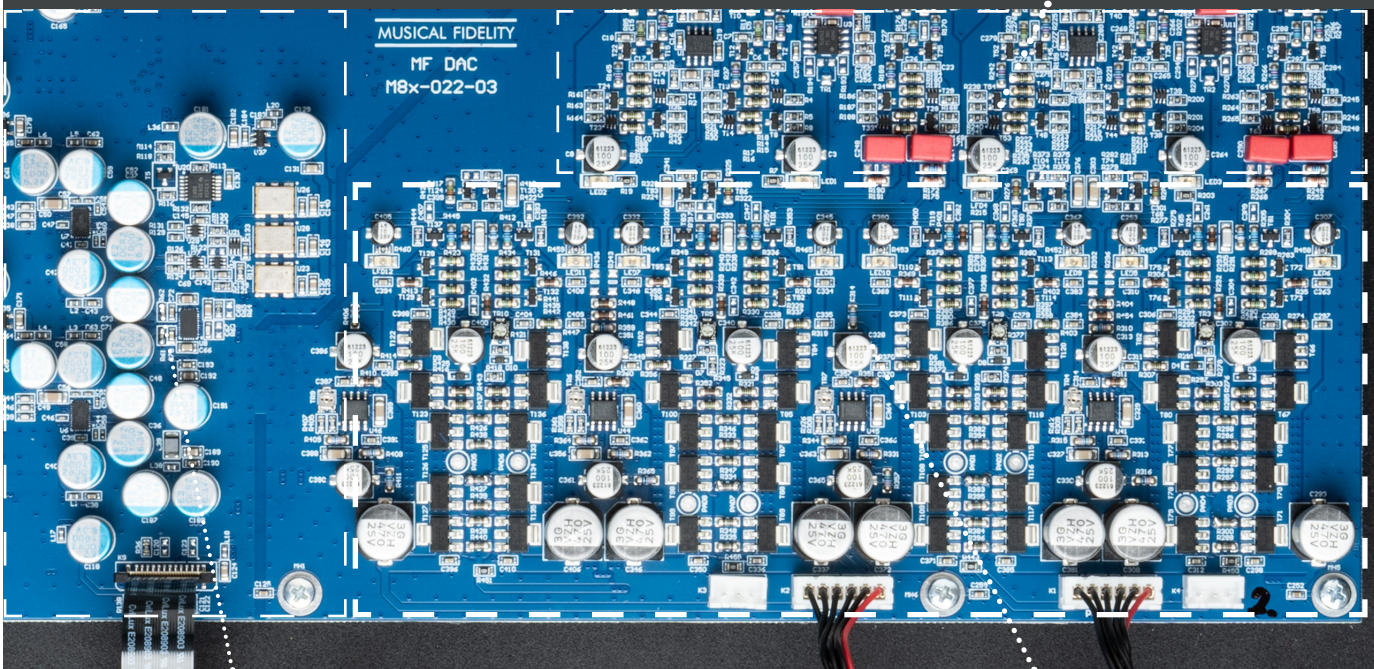

Dual differential DAC section

High-power fully balanced & discrete headphone amp

Fully Balanced

The M8x DAC employs fully balanced circuitry throughout. Dual mono DACs - two ES9038Q2M chips are used in dual differential mode - are feeding the fully differential balanced output and headphone amplifier stages.

A fully balanced design principle consists of a hot and a cold (also called + and -) signal. Both the + and - signal chains effectively carry the same musical information. A true balanced amplifier can now extract the final musical information out the +/- signals and subtract, remove, all noise that could potentially be added along the transmission.



Pseudo-balanced designs will not benefit from the advantages that balanced connections have to offer, like fully balanced amplifiers do.

In a true, fully balanced device, the + and - sections of both the left and right channel are treated individually, which doubles the amplifier sections by 2 as a result. You need twice as much space on the circuit board, twice as many electrical components and be twice as careful with planning your circuit board layout.

As a result, the M8x DAC excels at suppressing unwanted noise, errors and interferences and offers the best signal to noise ratio possible. The headphone amp shows increased output power coming from the fully balanced design.



A "pseudo-balanced" amplifier will not process the + and - signals independently, but add them together before they are processed.

Discrete Power

The M8x DAC displays our continued development of our Super Silent Power Transformers. Additionally it uses a sizable separate discrete power filtering and DC blocking PCB to keep noise and interference painstakingly low.

Industrial grade power sockets with EMI filter and DC blocker stop interferences and eliminate transformer hum. The encapsulated toroidal transformer with low core saturation has been purpose designed for digital audio and headphone applications alike. We achieve extremely low electromagnetic radiation, and more than enough headroom to properly power all the sensitive, discrete output and headphone amp stages.

Of special note: demands are drastically increased as everything in the M8x DAC is fully balanced! We are dealing with twice as many electrical components as regular single-ended designs!

The power supply for digital and analogue circuitry is carefully separated to provide immunity and isolation of the analogue amp and buffer stages from any possible digital HF interference.

Each output and headphone amp stage has a DC servo ensuring optimal DC mode. Powered by two high-quality symmetrical low-noise power supplies, one for each channel - all passively filtered and regulated.

DAC, output & headphone amp PCB

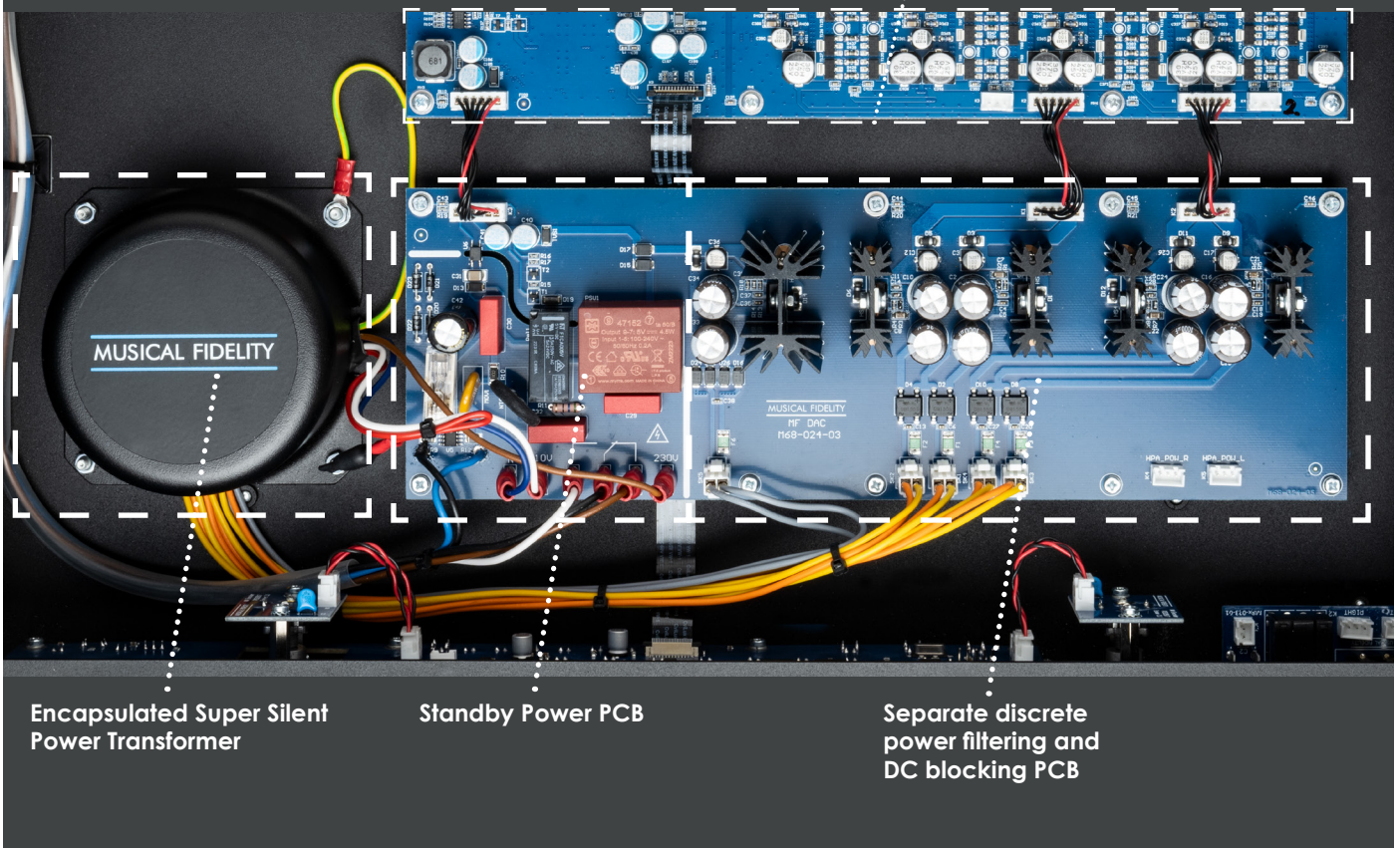

Encapsulated Super Silent Power Transformer

Standby Power PCB

Separate discrete power filtering and DC blocking PCB

Heroic Build Quality

The mechanical construction is uncompromisingly rigid and solid in typical Musical Fidelity tradition. Like on the M8x Vinyl, front, side and top panels are milled from extruded aluminium profiles and are extremely massive. The M8x DAC is basically immune against the effects of vibration from the environment.

The same can be said about electromagnetic immunity. The massive aluminium case acts as a Faraday cage. It protects the incredibly sensitive internals against outer electromagnetic fields.

Not using a big display on the front panel only increases this effect, as the cut out needed for it would drastically complicate things. The deliberate decision against a big display with flashing colours allows you to experience the music and only the music. We are only spending money in areas that go directly into the audio performance.



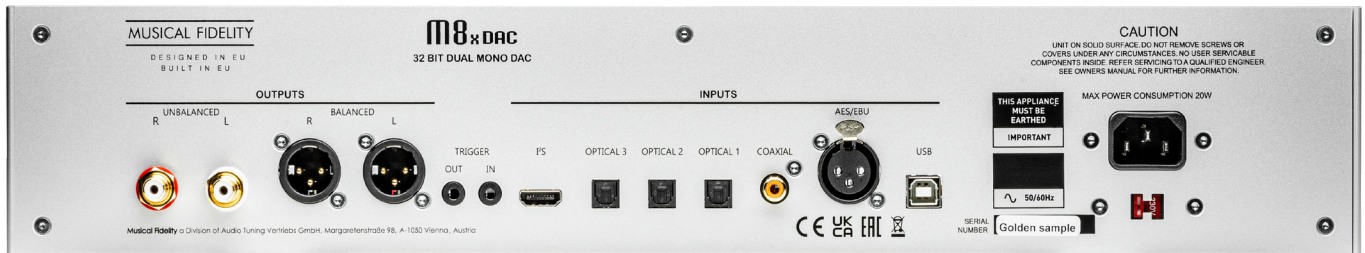

M8xDAC

SPECIFICATION

DAC

- DAC chip: 2x ES9038Q2M (dual mono) with 8x digital filter
- Frequency response: $< -0,1\text{dB}$ at 10Hz -20kHz
- Total correlated jitter: < 100 femtoseconds peak to peak
- Linearity: $< 0.1\text{dB}$ down to -130dB
- Channel separation: $< -114\text{dB}$ at 10kHz @ 0dBFS
- SNR: $> 100\text{dB}$ „A“-wt. at 1kHz @ 0dBFS
- THD+N: $< 0,001\%$ at 1kHz @ 0dBFS
- Output, digital 0dB level: RCA 2V RMS, XLR 4V RMS
- Output impedance: < 100 ohms

Headphone

- Outputs: 6.3mm stereo JACK unbalanced; 4-pin XLR balanced
- Power (balanced output): 3.9W / 8 ohms; 3.2W / 32 ohms; 400mW / 300 ohms
- Output impedance: < 5 ohms
- Frequency response: $< \pm 0,1\text{dB}$ at 20Hz-20kHz
- THD: $< 0,005\%$ at 1kHz @ -6dBFS
- SNR: $> 96\text{dB}$ „A“-wt. at 1kHz @ 0dBFS

Digital Inputs

- 1x USB input: USB Audio Class 2 requires USB 2.0 or higher on computer
- USB PCM sample rates: up to 768kHz

- USB DSD support: up to DSD256 via DoP and native DSD512
- MQA support: full MQA decoding by hardware
- 3x Optical input: up to 24bit / PCM 192kHz, MQA 384kHz, DoP DSD 64
- 1x Coaxial input: up to 24bit / PCM 192kHz, MQA 384kHz, DoP DSD 64
- 1x AES/EBU input: 1x up to 24bit / PCM 192kHz, MQA 384kHz, DoP DSD 64
- 1x CD I2S (MCLK out 16,9344MHz)

Analogue Outputs

- 1 pair line level RCA fix/var @ 2V RMS at 0dBFS
- 1 pair line level XLR fix/var @ 4V RMS at 0dBFS

Power requirement

- Mains voltages: 115/230VAC 50/60Hz (factory pre-set); 100VAC 50/60Hz (alternative)
- Consumption: 70 Watts maximum, < 0.5 W in standby

General Information

- Trigger In/Out
- Dimensions (WxHxD): 483 x 102 x 381 mm
- Weight: 10,6 kg net / 14 kg in shipping box